



# U-Bolt Saddle Clamp Installation

Saddle clamps **must be** used on a flat surface or customer supplied backing plate



Personal injury and property damage can occur without proper installation  
**Always use a lubricant such as Never Seez or Anti Seize to prevent the stainless steel hardware from seizing**

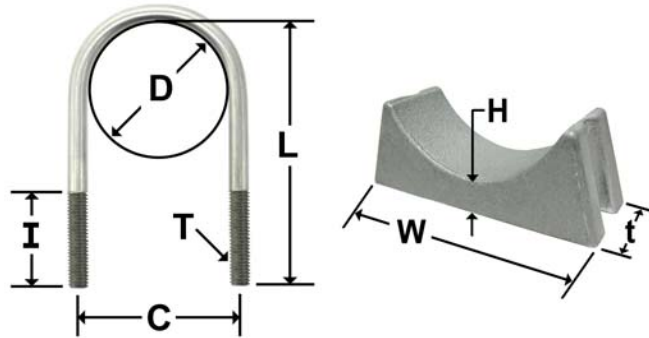

Nominal Size	DXE Part Number	D	L	C	I	T	Suggested Hole Size	W	H	t
0.50	<b>DXE-SAD-050A</b>	0.50	1.35	0.75	0.87	1/4-20	0.266 "H"	0.90	0.188	0.63
0.75	<b>DXE-SAD-075A</b>	0.75	1.81	1.00	0.87	1/4-20	0.266 "H"	1.13	0.188	0.75
1.00	<b>DXE-SAD-100A</b>	1.00	2.06	1.25	0.87	1/4-20	0.266 "H"	1.50	0.250	1.00
1.25	<b>DXE-SAD-125A</b>	1.25	2.37	1.50	0.87	1/4-20	0.266 "H"	1.75	0.250	1.00
1.50	<b>DXE-SAD-150A</b>	1.50	2.62	1.75	0.87	1/4-20	0.266 "H"	2.00	0.250	1.00
1.75	<b>DXE-SAD-175A</b>	1.75	3.00	2.00	1.00	1/4-20	0.266 "H"	2.31	0.250	1.00
2.00	<b>DXE-SAD-200A</b>	2.00	3.43	2.31	1.12	5/16-18	0.332 "Q"	2.62	0.375	1.00
2.00	<b>DXE-SAD-200B</b>	2.00	4.00	2.37	1.50	3/8-16	0.397 "X"	2.62	0.375	1.00
2.50	<b>DXE-SAD-250A</b>	2.50	4.18	2.81	1.25	5/16-18	0.332 "Q"	3.13	0.375	1.13
2.50	<b>DXE-SAD-250B</b>	2.50	4.75	2.87	1.75	3/8-16	0.397 "X"	3.13	0.375	1.13
3.00	<b>DXE-SAD-300A</b>	3.00	4.68	3.31	1.25	5/16-18	0.332 "Q"	3.62	0.375	1.25
3.00	<b>DXE-SAD-300B</b>	3.00	5.25	3.37	1.75	3/8-16	0.397 "X"	3.62	0.375	1.25
4.00	<b>DXE-SAD-400A</b>	4.05	5.56	4.43	1.50	3/8-16	0.397 "X"	4.80	0.438	1.50
4.50	<b>DXE-SAD-450A</b>	4.55	6.06	4.93	1.50	3/8-16	0.397 "X"	5.30	0.438	1.50

Suggested Hole Size: 0.266" is letter "H" drill bit, 0.332" is letter "Q" drill bit, and 0.397" is letter "X" drill bit.

\* All U-Bolts are formed from premium 18-8 stainless steel.\* All Saddles are cast 535.0 aluminum.\*

All Saddle Clamp Sets are supplied with 18-8 stainless steel nuts and lock washers. **Dimensions shown are in Inches.**



# V-Bolt Saddle Clamp Installation

Saddle clamps **must be** used on a flat surface or customer supplied backing plate



Personal injury and property damage can occur without proper installation  
**Always use a lubricant such as Never Seez or Anti Seize to prevent the stainless steel hardware from seizing**

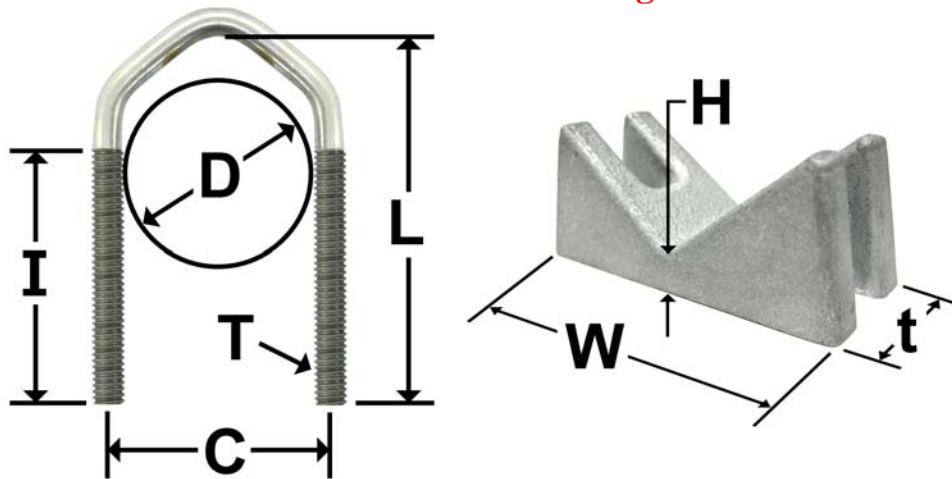

Nominal Size	DXE Part Number	D	L	C	I	T	Suggested Hole Size	W	H	t
0.50 to 1.75	DXE-CAVS-1P	1.75	3.438	1.968	2.313	1/4-20	0.266 "H"	2.313	0.250	1
0.50 to 1.75	DXE-CAVS-11P	1.75	3.438	2.063	2.313	5/16-18	0.332 "Q"	2.313	0.250	1
1 to 2	DXE-CAVS-2P	2.00	3.438	2.332	2.000	5/16-18	0.332 "Q"	2.835	0.375	1
2 to 3	DXE-CAVS-3P	3.13	4.610	3.500	1.750	3/8-16	0.397 "X"	4.250	0.500	2

All Dimensions are in Inches. Note: DXE-CAVS-1/11/2P saddle material is cast 319.0 aluminum DXE-CAVS-3P saddle material is cast 319.0 aluminum. Suggested Hole Size: 0.266" is letter "H" drill bit, 0.332" is letter "Q" drill bit, and 0.397" is letter "X" drill bit.

*These are NOT Automotive Muffler Clamps*

©DX Engineering 2009

P.O. Box 1491 Akron, OH 44309-1491 USA

Phone: 800-777-0703 - Tech Support and International: 330-562-3200

Fax: 330-572-32679 - E-mail: [DXEngineering@DXEngineering.com](mailto:DXEngineering@DXEngineering.com)

Rev. 11